

SPECIFICATION

DT-2EWU-IBC-1918

DENIMOTECH
THE ROAD AHEAD



EASY WEIGH UNIT

CHEMICAL DOSAGE UNIT
FOR BATCH EMULSION PLANTS
CAPACITY: 2 IBC Containers for 2 chemicals

Manufacturer:

*DENIMOTECH A/S
Haandvaerkervangen 12
DK-5792 Aarslev
Denmark*

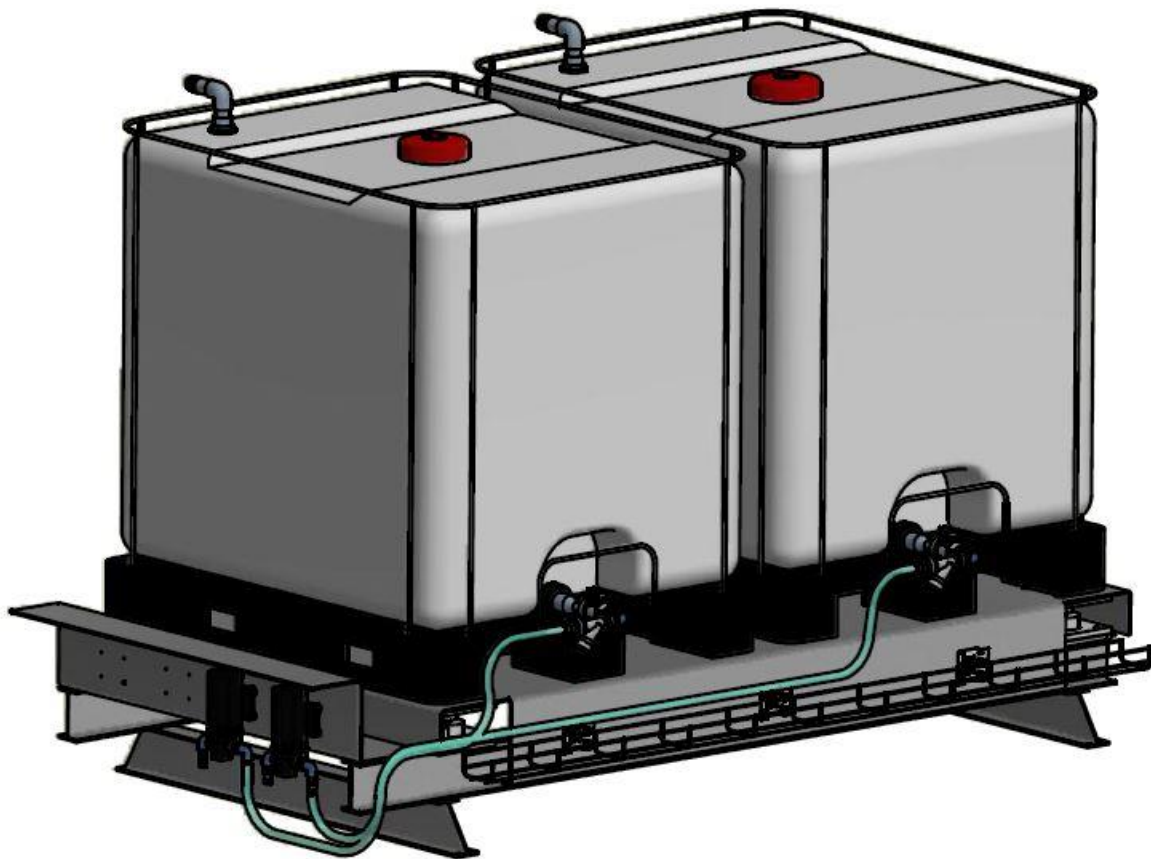

Easy weigh Unit with IBC tanks, pumps etc.

PROCESS DESCRIPTION

The Easy Weigh Unit is a dosage unit designed to control and ensure easy and accurate dosing of chemicals to the bitumen emulsion batch plant. The Easy Weigh Unit can fit all DENIMOTECH emulsion batch plants. It is a perfect match to both advanced fully automatic plants and the simplest manually operated systems.

The unit is designed with loading cells underneath the frame to weigh the total content in the IBC tank. Thereby it controls and measures the correct flow of chemicals, from the Easy Weigh Unit to the water batch tank in, the bitumen emulsion plant.

The process includes the following steps:

1. The IBC tanks are filled with chemicals, ex. acid, stabilizer, emulsifier etc.
2. Open the valve for the IBC tank, to start the production.
3. The pump is controlled by the PLC system and pumps the chemical from the IBC tank to the water batch tank.
4. Each IBC tanks can be with options as the following:
 - a. Agitator
 - b. Heating elements
 - c. Insulation
5. Each IBC tank has its own line with valves and connections to the batch tank on the DENIMOTECH emulsion plant. This way there are no hoses or pipes that have different chemicals inside, because some chemicals have a negative effect on others.
6. The loading cells control the amount of chemicals that are pumped into the batch tanks.

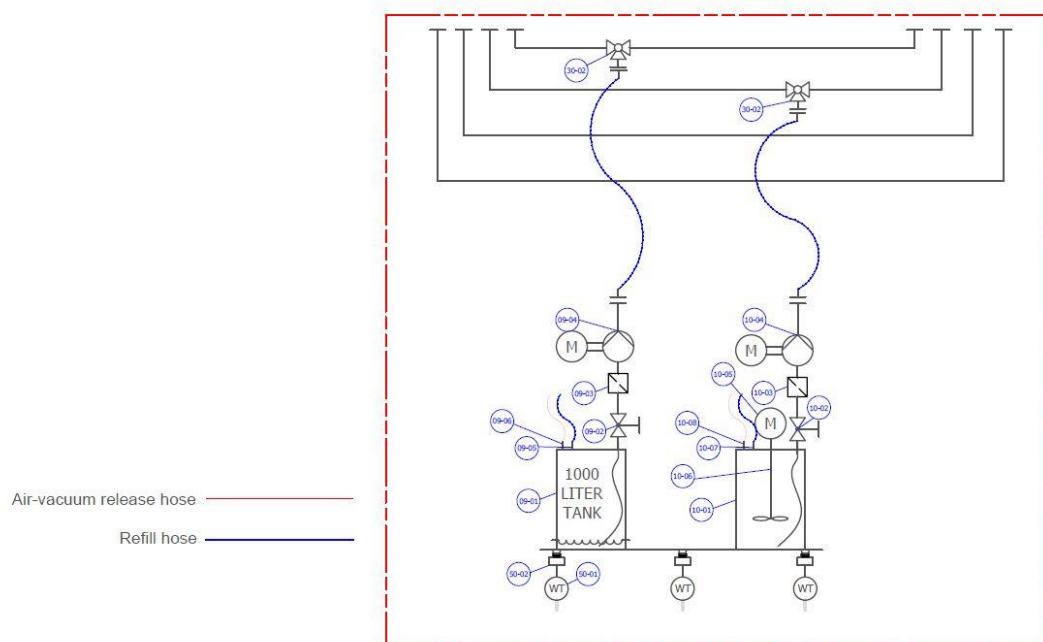

Figure 1: Ex. on an Easy Weigh Unit flow-diagram / flow-process.

GENERAL FEATURES

High and constant product quality

The DENIMOTECH Easy Weigh Unit, EWU, for adding chemicals into the water batch tanks in an DENIMOTECH emulsion plant.

Easy operation

The unit is operated by control cabinet start and stop functions together with the weighing display that continuously show the weight contents of the containers, and the chemicals are added in a user-defined sequence.

The unit measures the direct mass (kg).

The complete unit is mounted on a frame for easy access to control devices and process supervision. The complete unit can be placed somewhere beside the DENIMOTECH emulsion plant or inside a container along with a DENIMOTECH emulsion plant.



The electrical controls are collected in one panel, which is mounted directly on the frame. If the Easy Weigh Unit is built inside a container along with a DENIMOTECH emulsion plant, the control panel is placed beside the control panel for the emulsion plant for easy and integrated operation.

One person is enough to operate the complete plant including sampling and production quality testing, reception of incoming raw material and loading out chemicals, regardless of it is integrated in the emulsion plant or as a standalone unit.

Operational reliability

The plants are designed and build in full compliance with the latest European Standards of process machinery including mechanical and electrical design as well as documentation.

Only high-quality components and materials are used to ensure best possible operational reliability in tropical and tempered climates as well as industrial environment. The unit with all the equipment is highly corrosion resistant to nearly all chemicals, including concentrated hydro chloric acid.

All parts are completely numbered and identifiable in manuals and part lists. Extensive manuals go with the plants and include process and electrical diagrams, maintenance and service instructions and technical data for the various components and systems.

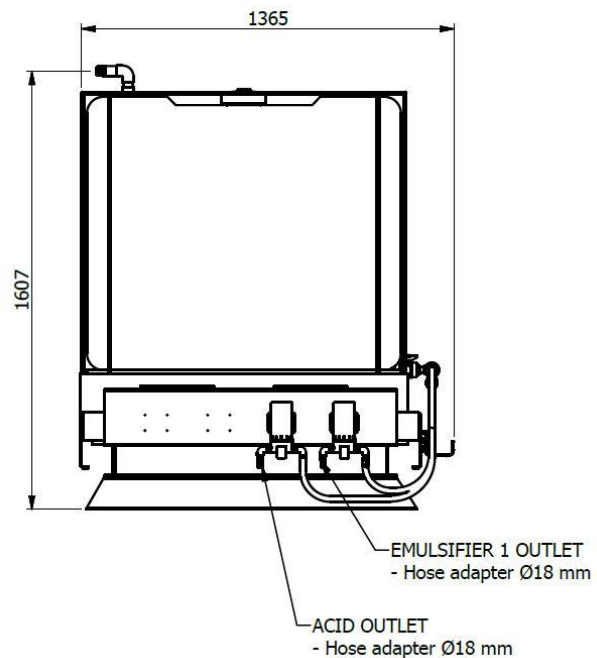

Fast and easy installation

The Easy Weigh Unit are fully assembled with all the equipment. Calibration and testing are done at the factory prior to shipment. This brings down the installation and commissioning time.

The skid is sized and build to allow easy transport either as a standalone model, or in a standard shipping containers, which simplifies handling and gives low freight costs and excellent protection during transport.

The Easy Weigh Unit can easy be connected to the DENIMOTECH emulsion plant by PVC hoses. (The hoses are delivered with the Easy Weigh Unit) The DENIMOTECH emulsion plant either already has the hose connection installed in the batch tanks and container wall or it can easily be installed in the existing plant.

If the Easy Weigh unit is placed inside the container along with the DENIMOTECH emulsion plant the connection are done by fixed PVC piping.

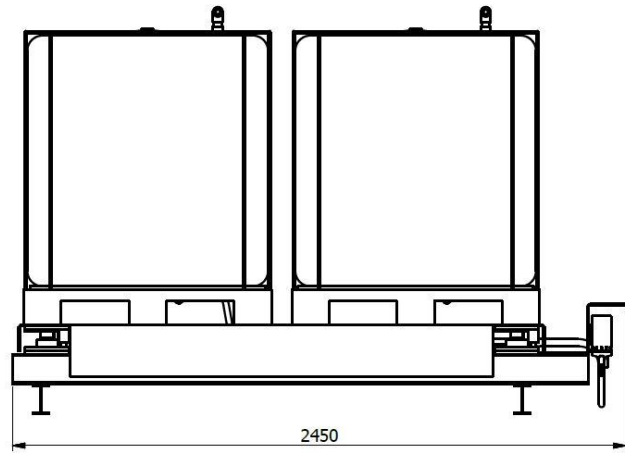

EQUIPMENT SPECIFICATION

Loading cells

Under the frame there are installed 6 loading cells to measure the content in the IBC tank and are used to control the flow.

Pump

There are 2 pumps, one for each chemical line. The pumps are connection by hoses and controlled by the PLC system. The pump is resistance to all chemicals.



Agitator

In the IBC tank there can be installed an agitator to ensure homogeneity mass in ex. The stabilizer.

Heating

In the IBC tank there can be installed a heating element to ensure the temperature of ex. Emulsifiers.

Other features

- The level in the chemical tanks is monitored and a warning will be given in case of a critical low level.
- All programmed injection sequences can be easily stored as a recipe in the recipe database and reloaded for future use.
- Small quantities of acid can be post-added to ensure the required pH value in the water phase batch tank.

TECHNICAL DATA

Model	EWU-IBC-2	Model
Chemical Storage System	-	IBC Containers (max 1000 liter)
Number of chemical dosage lines	-	2
Max total chemical capacity (net.)	Kg	2250
Minimum display	Kg	0,050
Dosage Pumps, flow rate (all lines)	Liter/min.	7
Repeatability (std. deviation)	Kg	0,060
Agitator, stabilizer	KW	0,75
Control system	-	Control Cabinet
Human Machine Interface (HMI)	-	Touch buttons
Operating temperature	°C	0 to 40
Mass (empty)		500 kg
Product approval	-	CE marked

DenimoTech
the road ahead



DenimoTECH A/S
Haandvaerkervangen 12
DK-5792 Aarslev
Denmark

tel.: +45 6390 5000
email: sales@denimotech.com
www.denimotech.com

